

ATTENTION

NO ONE SHOULD BE ALLOWED ON ANY G2T TRUSS UNTIL ALL HANGERS & CROSS BRIDGING, IF REQ'D, AND TEMPORARY BRACING ARE IN PLACE AND NAILED SECURELY. SERIOUS ACCIDENTS MAY OCCUR UNLESS CARE IS TAKEN TO PROPERLY BRACE DURING CONSTRUCTION. THIS DETAIL SHOULD BE USED AS A GUIDELINE FOR BRACING.

STACK BUILDING MATERIALS OVER WALLS, GIRDERS OR BEAMS ONLY

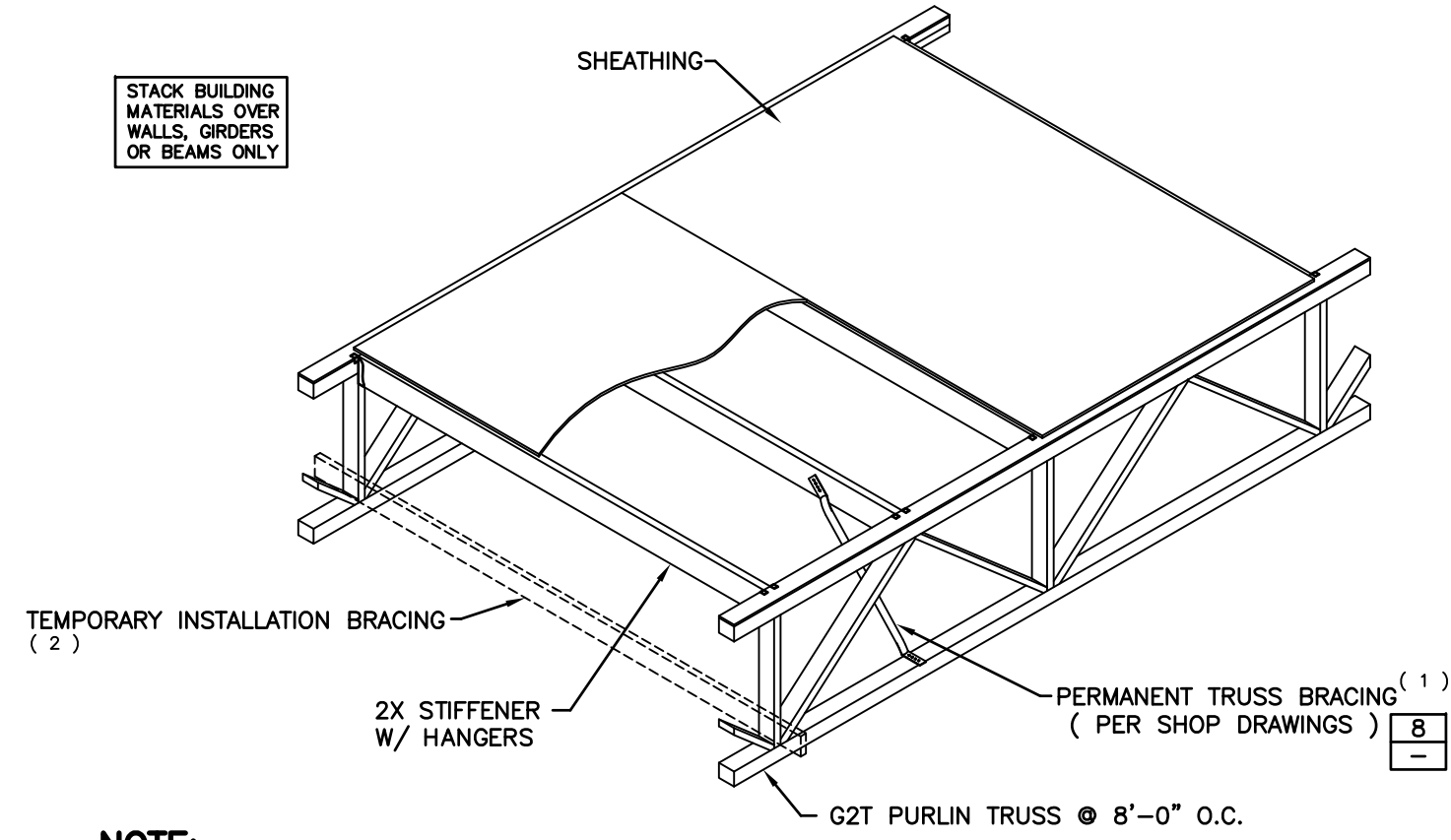

NOTE:

- (1) PERMANENT BRACING SHALL BE PER FABRICATOR'S RECOMMENDATIONS. IF PERMANENT BRACING IS USED AS THE INSTALLATION BRACING, IT MUST BE INSTALLED AS EACH TRUSS IS PLACED. A MINIMUM OF TWO (2) INSTALLATION BRACES ARE REQUIRED AT ALL SPANS GREATER THAN 32'-0".
- (2) INSTALLATION BRACING IN ADDITION TO OR IN LEIU OF PERMANENT TRUSS BRACING TO BE DESIGNED AND INSTALLED BY THE INSTALLATION CONTRACTOR.

1 ERECTION BRACING

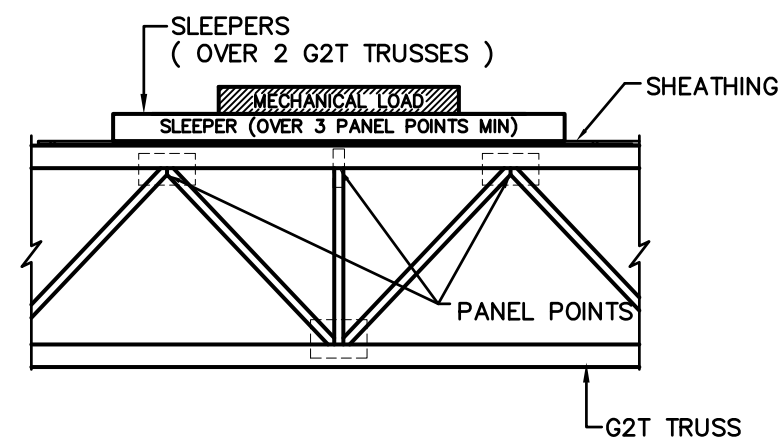

PARALLEL CONDITION

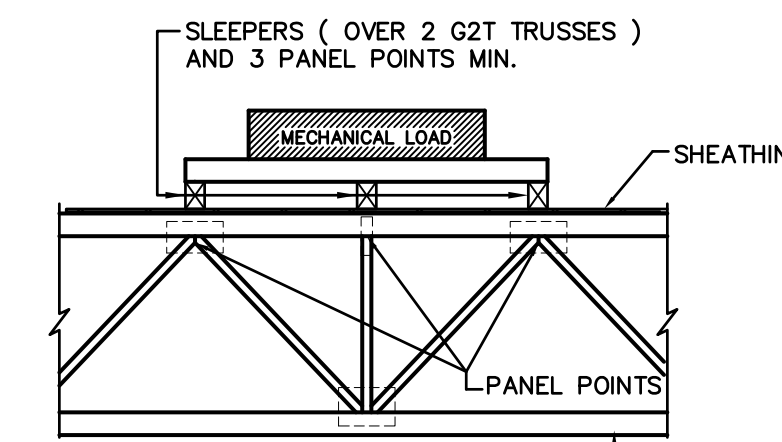

PERPENDICULAR CONDITION

NOTES

- COORDINATE MECHANICAL LOCATIONS WITH LAYOUT AND G2T CALCULATIONS
- SLEEPERS MUST BE LOCATED AT PANEL POINTS

2 MECHANICAL LOADS ON G2T TRUSSES

G2T TRUSS NAILING CHART (MINIMUM ON CENTER SPACING)

NAIL TYPE	NAIL SIZE	MSR (M)		LSL (L)		LVL (V)			
		FACE	EDGE	FACE	EDGE	FACE	EDGE		
8d	BOX	0.113"x2 1/2"	2"	2"	3"	3"	1"	2"	1"
	COMMON	0.131"x2 1/2"	2"	2"	3"	3"	1"	3"	1"
10d	BOX	0.128"x3"	2"	2"	3"	3"	1"	3"	1"
	COMMON	0.148"x3"	3"	4"	3"	4"	1"	4"	1"
12d	BOX	0.128"x3 1/4"	3"	2"	3"	3"	1"	3"	1"
	COMMON	0.148"x3 1/4"	3"	4"	3"	4"	1"	4"	1"
16d	BOX	0.135"x3 1/2"	3"	3"	3"	4"	2"	3"	2"
	SINKER	0.148"x3 1/4"	3"	4"	3"	4"	2"	4"	2"
COMMON	0.162"x3 1/2"	4"	6"	3"	6"	2"	6"	2"	

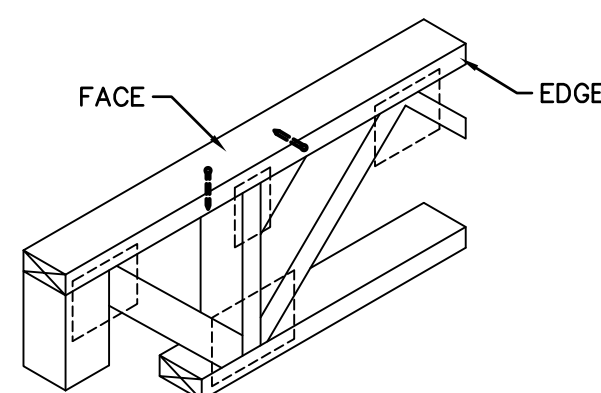

G2T TRUSS

3 NAILING CHART

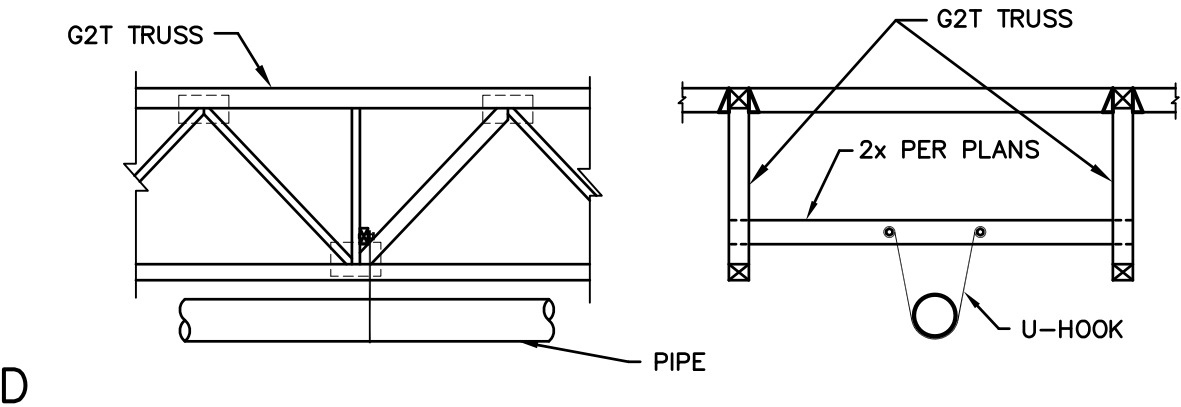
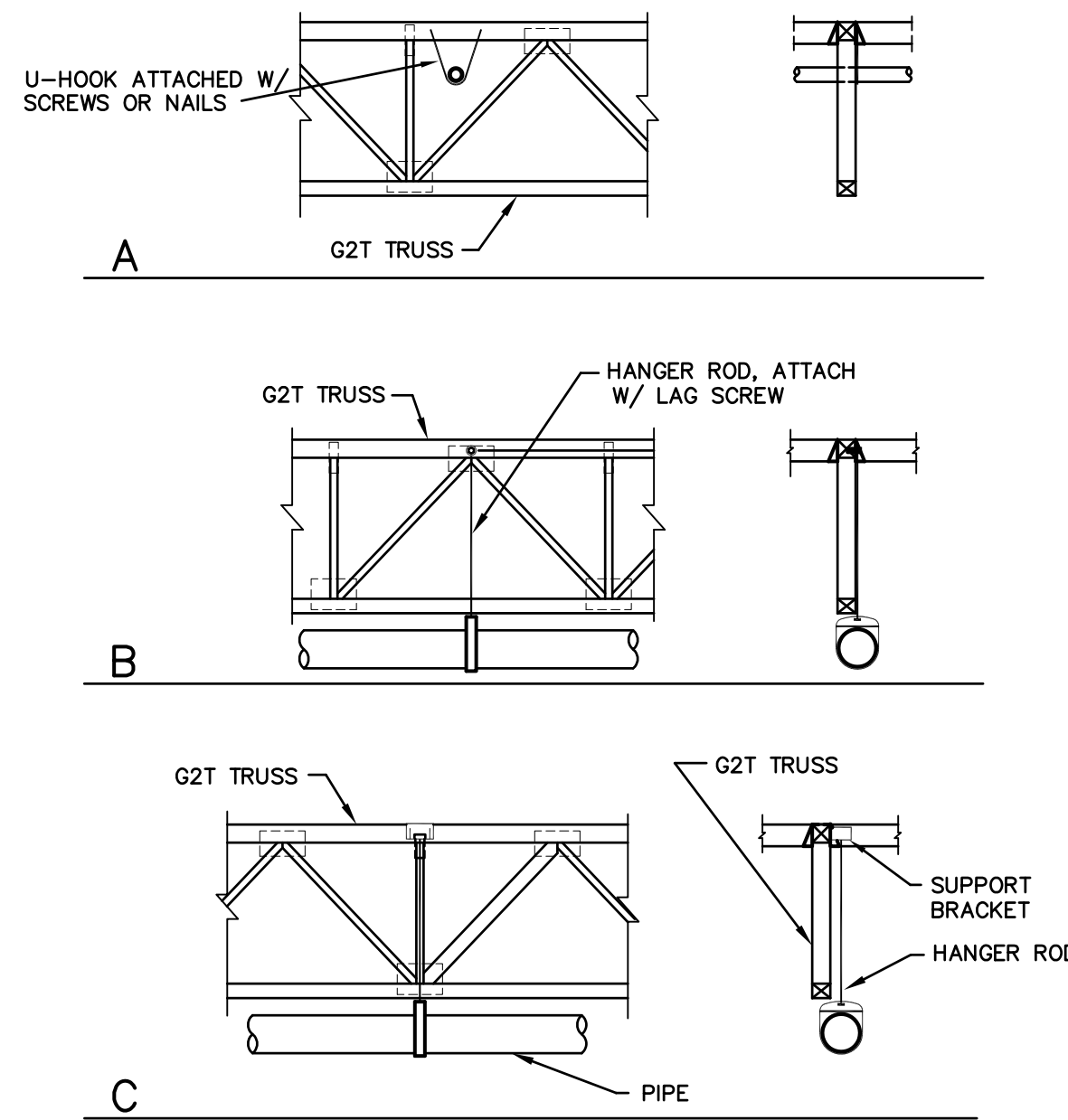

NOTES:

- WOOD SCREWS WITH A MAXIMUM DIAMETER OF 5/16" MAY BE USED ANYWHERE ON THE TOP CHORD OF THE G2T TRUSS WITHOUT PRE-DRILLING A PILOT HOLE, UNLESS NOTED OTHERWISE ON PLANS.
- BOLTS OR LAG SCREWS HAVING A DIAMETER OF 3/8" OR GREATER MUST BE LOCATED IN THE CONNECTOR PLATE AT THE TOP CHORD OF THE G2T TRUSS.
- BOLTS OR LAG SCREWS HAVING A DIAMETER OF 1/2" OR GREATER MUST HAVE PRE-DRILLED HOLES LOCATED IN THE CONNECTOR PLATE AT THE TOP CHORD OF THE G2T TRUSS.
- DO NOT DRILL HOLES, DRIVE HEAVY SCREWS, OR USE LAG BOLTS IN THE BOTTOM CHORD OF G2T TRUSS.
- COORDINATE ATTACHMENT OF SPRINKLER PIPE 4" DIAMETER AND LARGER WITH TRUSS LAYOUT AND CALCULATIONS.
- BOLTS OR LAG SCREWS INTO THE TOP CHORD SHALL BE LIMITED TO A MAXIMUM DIAMETER AS FOLLOWS: 1/2" @ G2T44; 7/8" @ G2T46
- NOTE: ALL CONNECTIONS, CLAMPS, HANGERS, RODS, OR SUPPORT ETC.... SHALL BE IN ACCORDANCE WITH NFPA 13

4 FIRE SPRINKLER ATTACHMENT DETAIL

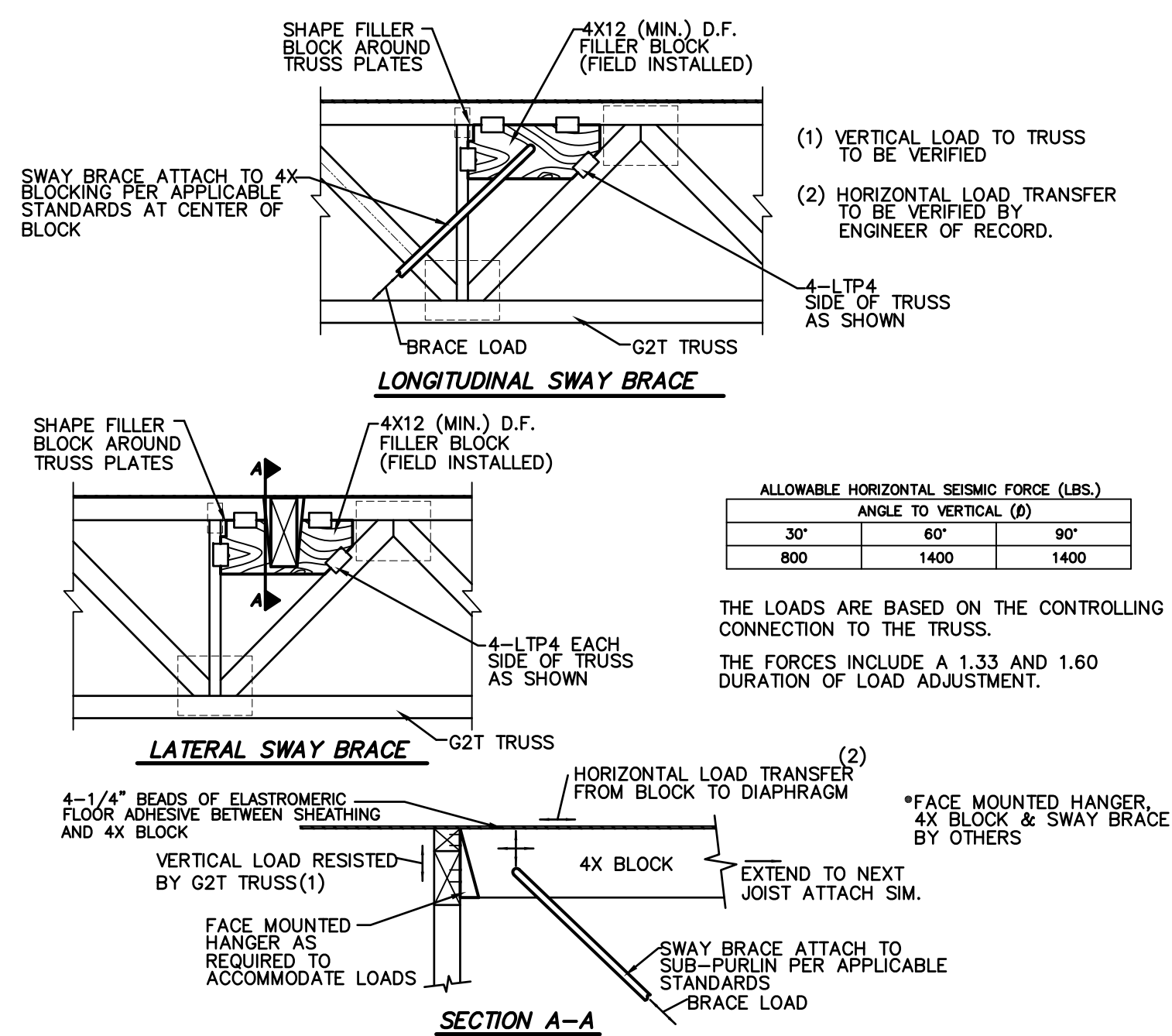

ALLOWABLE HORIZONTAL SEISMIC FORCE (LBS.)	ANGLE TO VERTICAL (°)
300	60°
1400	90°
1400	1400

THE LOADS ARE BASED ON THE CONTROLLING CONNECTION TO THE TRUSS.
THE FORCES INCLUDE A 1.33 AND 1.60 DURATION OF LOAD ADJUSTMENT.

5A FIRE SPRINKLER SWAY BRACE DETAIL

6 G2T TRUSS GENERAL DIMENSIONS

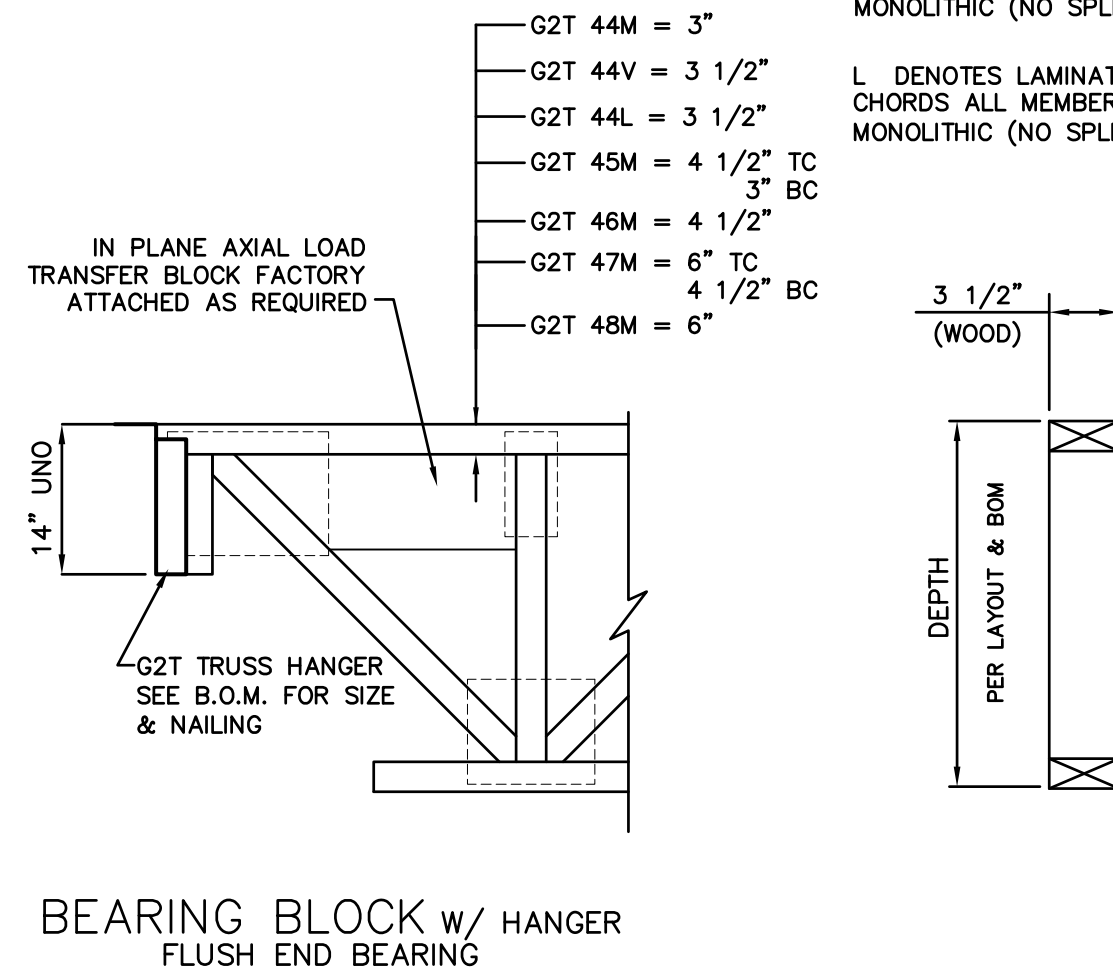

6 G2T TRUSS GENERAL DIMENSIONS

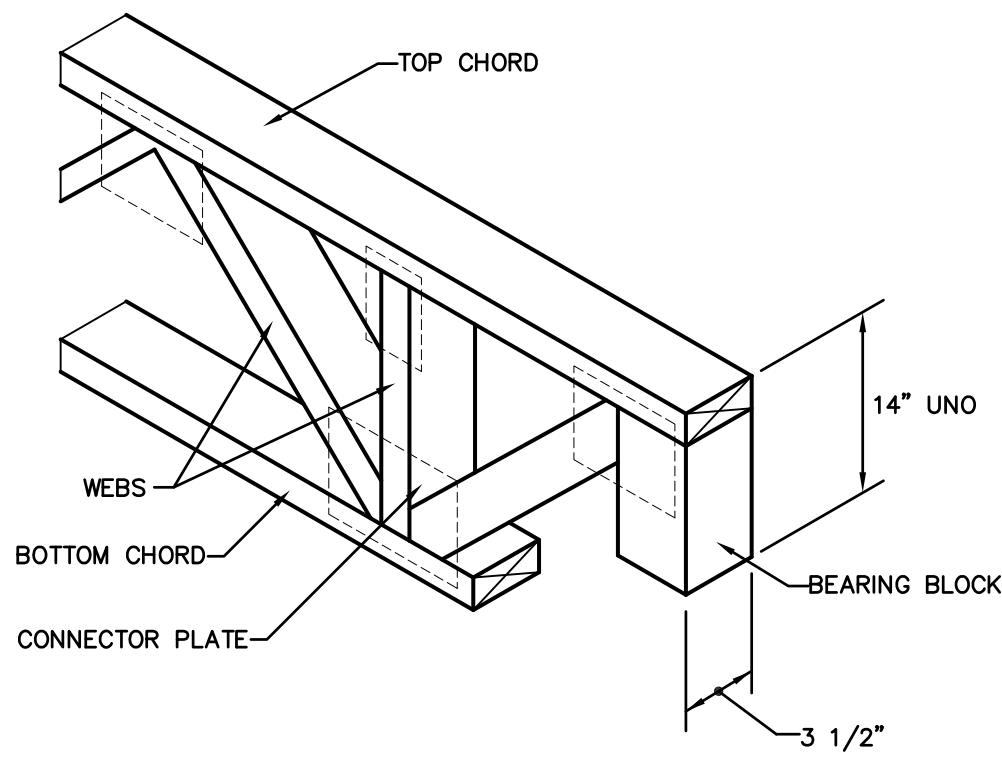

7 G2T TRUSS W/ BEARING BLOCK

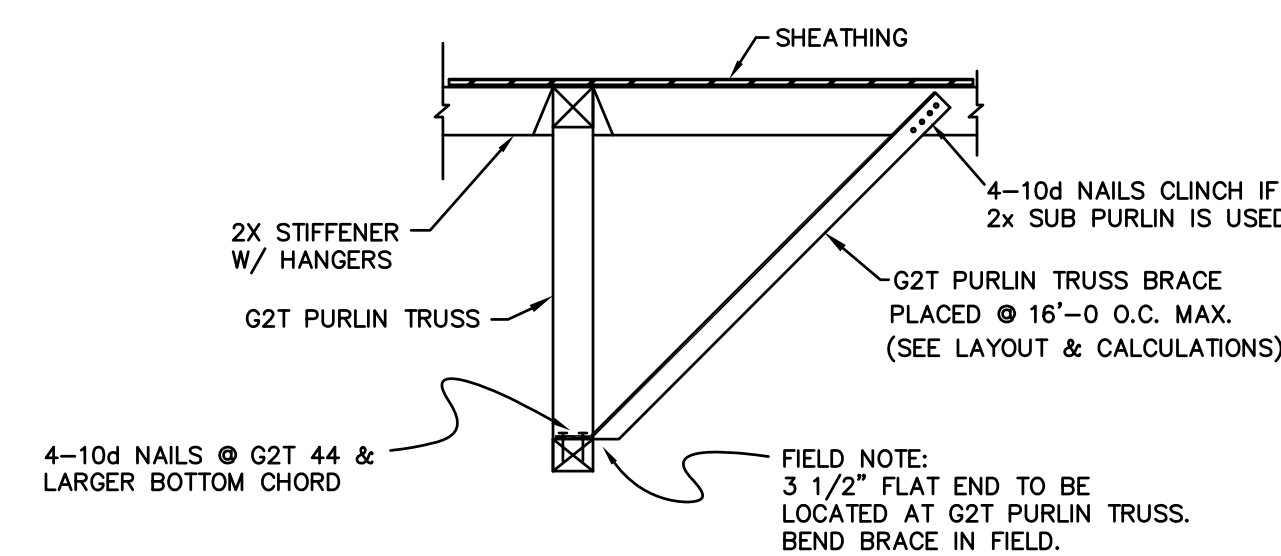

8 PERMANENT G2T ERECTION BRACE

G2T PURLIN JOIST PRODUCT COVER SHEET

JOB SITE HANDLING OF G2T OPEN WEB TRUSSES

IT IS THE BUILDING CONTRACTOR'S RESPONSIBILITY TO UNLOAD THE G2T TRUSSES FROM THE TRUCK AND FOR ALL HANDLING THEREAFTER. THE G2T OPEN WEB TRUSS GUARANTEE ONLY APPLIES AS LONG AS THE PRODUCT IS NOT DAMAGED OR ALTERED IN ANY WAY, IS INSTALLED IN A WORKMANLIKE MANNER. G2T TRUSSES WILL BE DELIVERED TO THE JOBSITE IN BUNDLES BANDED TOGETHER FOR HANDLING EASE. TO AVOID DAMAGE, TRUSSES SHOULD BE LEFT IN THESE BUNDLES UNTIL READY FOR INSTALLATION IN THE STRUCTURE. A CARELESS CRANE OR FORKLIFT OPERATOR CAN DAMAGE G2T TRUSSES. NEVER HANDLE G2T TRUSSES FLAT - KEEP IN AN UPRIGHT POSITION.

STORAGE OF G2T OPEN WEB TRUSSES

DURING STORAGE AT THE JOBSITE, KEEP G2T TRUSSES IN AN UPRIGHT POSITION. THE BUNDLES SHOULD BE SUPPORTED ON LEVEL STICKERS TO KEEP THE G2T TRUSSES OUT OF THE MUD AND DIRT. STACKING OF BUNDLES IS PERMITTED IF AN ADEQUATE NUMBER OF STICKERS ARE PROVIDED TO PREVENT DAMAGE AND NORMAL SAFETY PRECAUTIONS ARE FOLLOWED. ALL GLUE USED IN G2T TRUSSES IS WATER PROOF. HOWEVER, LONG EXPOSURE TO WATER AND SUN WILL CAUSE SOME DETERIORATION AND CHECKING OF WOOD. G2T TRUSSES SHOULD RECEIVE THE SAME PROTECTION FROM WEATHER AS OTHER WOOD PRODUCTS.

TYPICAL G2T PROJECT NOTES:

- FOR NOTES, DETAILS, AND DIMENSIONS NOT ON THESE SHOP DRAWINGS, REFER TO PROJECT PLANS.
- SEE BILLS OF MATERIAL FOR ITEMS FURNISHED.
- ALL CLOUDED NOTES, DIMENSIONS, ETC. REQUIRE VERIFICATION AND MUST BE MARKED EITHER "OK" OR THE CORRECT INFORMATION PROVIDED BY CUSTOMER, PRIOR TO RETURN TO BEING RETURNED FOR FABRICATION.
- PLEASE BE AWARE THAT ANY CLOUDED ITEMS NOT ACKNOWLEDGED WILL REQUIRE CONTACT WITH RESPONSIBLE PARTIES AND MAY CAUSE DELAY IN THE PROCESSING OF YOUR ORDER.
- PLEASE VERIFY THAT ALL INFORMATION PROVIDED HEREWITH REFLECTS THE LATEST AVAILABLE PROJECT INFORMATION AND THAT ALL G2T TRUSS LENGTHS CORRESPOND WITH ACTUAL FIELD DIMENSIONS PRIOR TO BEING RETURNED FOR FABRICATION.
- ALL BRACING SHOWN IS INTEGRAL TO THE G2T OPEN WEB TRUSS SYSTEM AND SHOULD BE TEMPORARY OR ERECTION BRACING. THE G2T OPEN WEB TRUSS WILL NOT SAFELY SUPPORT LOADS UNTIL FULLY BRACED, FULLY ATTACHED TO BEARING WALLS OR BEAMS, AND SHEATHING, BY OTHERS IS PROPERLY INSTALLED (SEE LAYOUTS AND DETAILS).
- POINT LOADS THAT EXCEED 100 LBS. AS INDICATED ON THE LAYOUT HEREIN.
- INSTALLATION OF G2T OPEN WEB TRUSSES MUST FOLLOW ANY ADDITIONAL REQUIREMENTS INDICATED ON THE LAYOUTS AND IN THE CALCULATIONS.
- ALL G2T OPEN WEB TRUSSES ARE DESIGNED FOR UNIFORM LOADS AND CONCENTRATED LOADS NOTED ON THESE DRAWINGS AND CALCULATIONS. TEMPORARY CONSTRUCTION LOADS WHICH CAUSE STRESSES BEYOND DESIGN CRITERIA ARE NOT PERMITTED.
- ALL 2X, 4X, 6X ETC. FRAMING TO BE SUPPLIED BY OTHERS, UNO. (FMBO).
- METAL STRAPS AND/OR TIES USED FOR SEISMIC PURPOSES THAT ARE NAILED TO THE TOP OF THE TOP CHORD ARE TO USE 10d NAILING AT NO LESS THAN 3" @ IN A ROW. ACCEPTABLE STRAPS FOR G2T TOP CHORDS ARE LTI, LSTI, MSTI AND PAL.
- G2T OPEN WEB TRUSS ARE NOT DESIGNED TO SUPPORT ANY FIRE SPRINKLER AND/OR MECHANICAL LOADS OTHER THAN WHAT IS SHOWN ON THESE SHOP DRAWINGS, AND OR WHAT HAS BEEN PROVIDED IN THE DESIGN DEAD LOAD(S).
- THE PLACEMENT OF THE MECHANICAL UNITS AND SPRINKLER MAINS ARE TO BE AS NOTED ON THESE SHOP DRAWINGS. THE SUPPORTING TRUSSES HAVE BEEN SPECIFICALLY DESIGNED TO ACCOMMODATE THESE ITEMS. ALL COMPONENTS TRANSFERRING LOADS TO THE TRUSSES SHALL BE DESIGNED AND INSTALLED IN ACCORDANCE WITH THE DETAILS CONTAINED WITHIN THESE DRAWINGS.
- G2T TRUSS DESIGNS ARE IN ACCORDANCE WITH THE CURRENT ADOPTED EDITION OF THE IBC, CBC, AND NATIONAL DESIGN SPECIFICATION, AND CONFORM TO CURRENT ICC-ES REPORT.

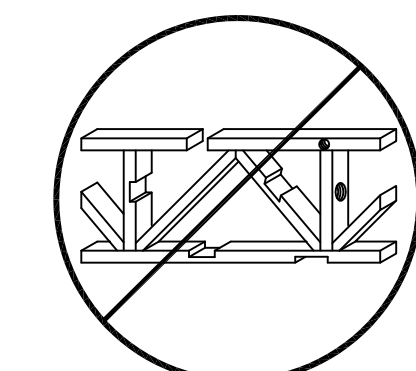

9 G2T TRUSS NOTES

WARNING:
Drilling, sawing, sanding or machining wood products generates wood dust and other substances known to cause cancer. Avoid inhaling dust generated from wood products or use a dust mask or other safeguards for personal protection.
Wood products emit chemicals known to cause birth defects or other reproductive harm.

LEGEND / ABBREVIATIONS

- SEE PROJECT PLANS FOR OTHER ABBREVIATIONS AND SYMBOLS USED.
- DETAIL (ON SHOP DRAWINGS)
 - PROJECT PLAN DETAIL (PER PLANS)
 - START G2T TRUSS LAYOUT @ o/c SPACING
 - STRONGBACK LOCATION
 - DIRECTION OF ROOF SLOPE
- FMBO = FRAMING MATERIAL BY OTHERS
VF = VERIFY IN FIELD
NIC = NOT IN CONTRACT
UNO = UNLESS NOTED OTHERWISE
FSML = FIRE SPRINKLER MAIN LINE
FIT = FACE TO FACE (CLEAR SPAN OF TRUSS)
MTL = MANUFACTURED TRUSS LENGTH
OTCL = OVERALL TOP CHORD LENGTH (SLOPE LENGTH)
LBS = POUNDS
PSF = POUNDS PER SQUARE FOOT
PLF = POUNDS PER LINEAL FOOT
MFR. = MANUFACTURER
> = GREATER THAN (< = LESS THAN)
B/O.C. = ON CENTER SPACING
B/L(S) = BILL(S) OF MATERIAL (8 1/2 x 11 SHEETS)
DBL = DOUBLE MEMBER (TPL = TRIPLE MEMBER)

REVISIONS	DATE	DESCRIPTION
1		
2		
3		
4		
5		

GROCERY OUTLET STORE #321 (GVP)
2308 DEL PASO BLVD
SACRAMENTO, CA 95815

ENGINEER
SKM
916-492-8200
ARCHITECT
HMR ARCHITECTS
916-756-2724
CUSTOMER
SD OCHS CONSTRUCTION INC
916-660-9480

G2 NATIONAL
Evolution in Wood-Framed Structure.
G2 NATIONAL LLC
2165 GREEN VISTA DRIVE # 212 SPARKS, NEVADA 89431

11/02/2017
PN-13168
SHEET
1 OF 5

ATTENTION

NO ONE SHOULD BE ALLOWED ON ANY JOIST UNTIL ALL HANGERS, BLOCKING, CROSSBRIDGING, IF REQ'D, AND TEMPORARY BRACING ARE IN PLACE AND NAILED SECURELY. SERIOUS ACCIDENTS MAY OCCUR UNLESS CARE IS TAKEN TO PROPERLY BRACE DURING CONSTRUCTION. THIS DETAIL SHOULD BE USED AS A GUIDELINE FOR ERECTION BRACING.

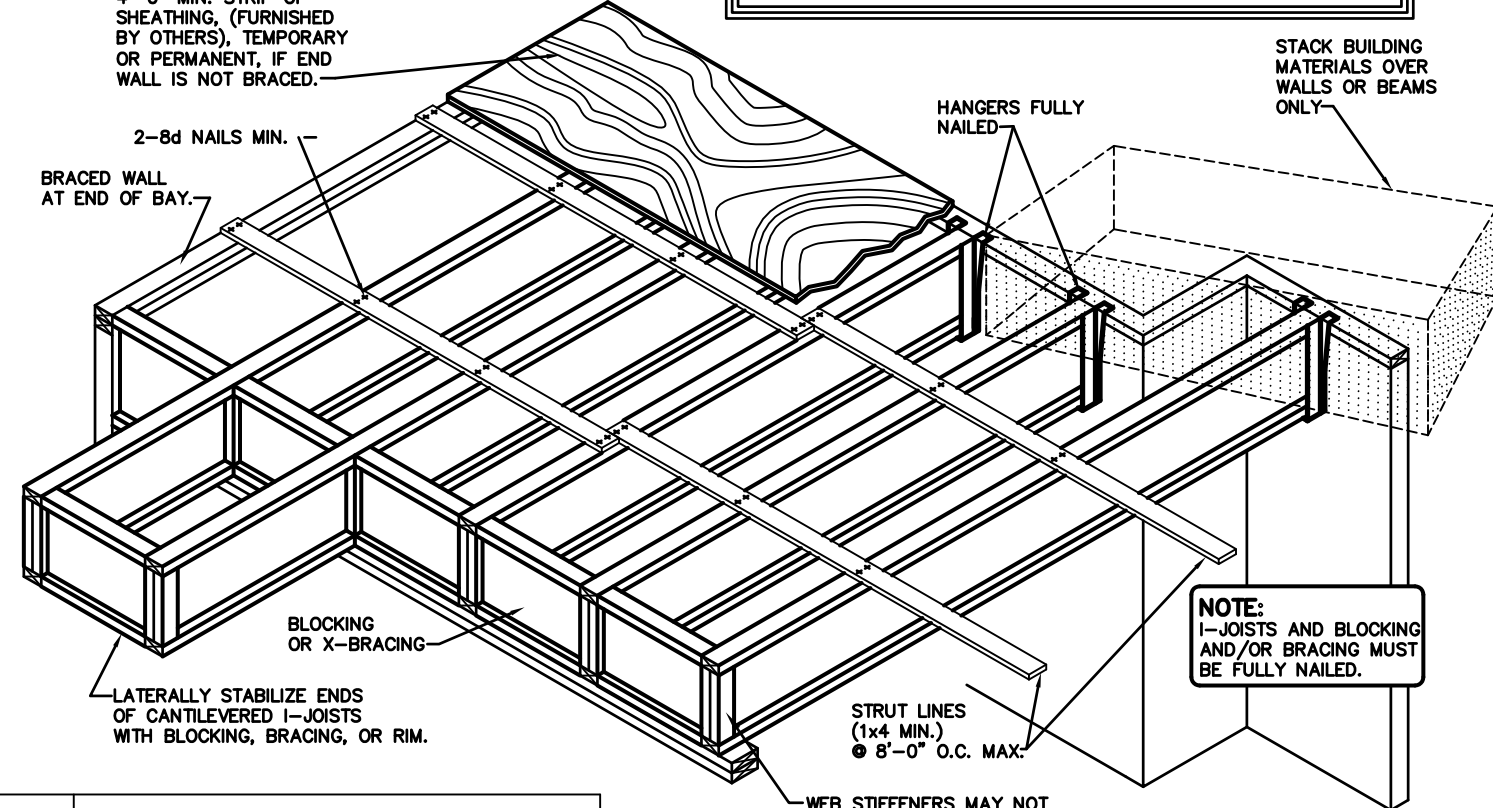

1 ERECTION BRACING

N.T.S.

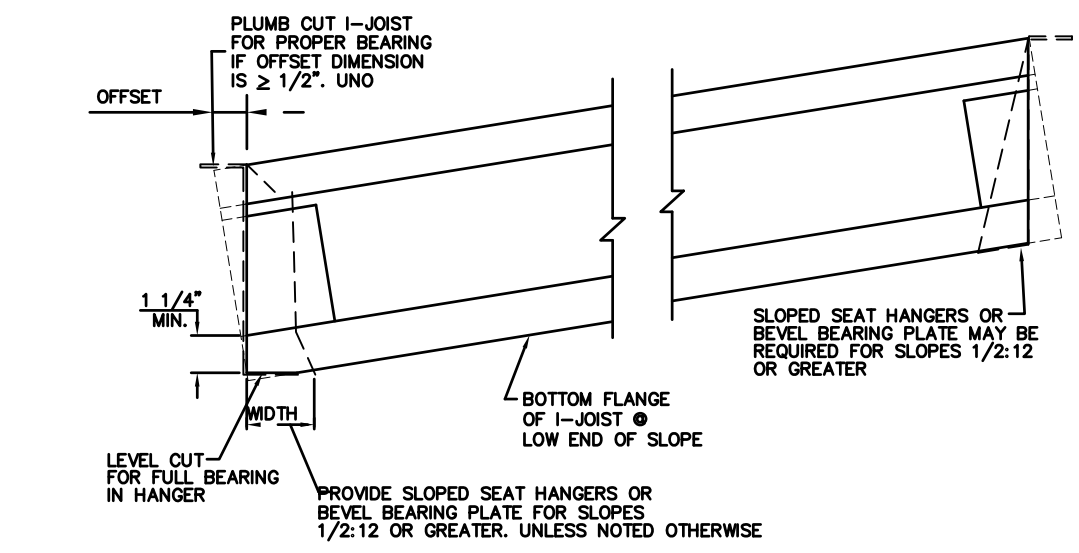

3 SLOPED END BEARING DETAIL

N.T.S.

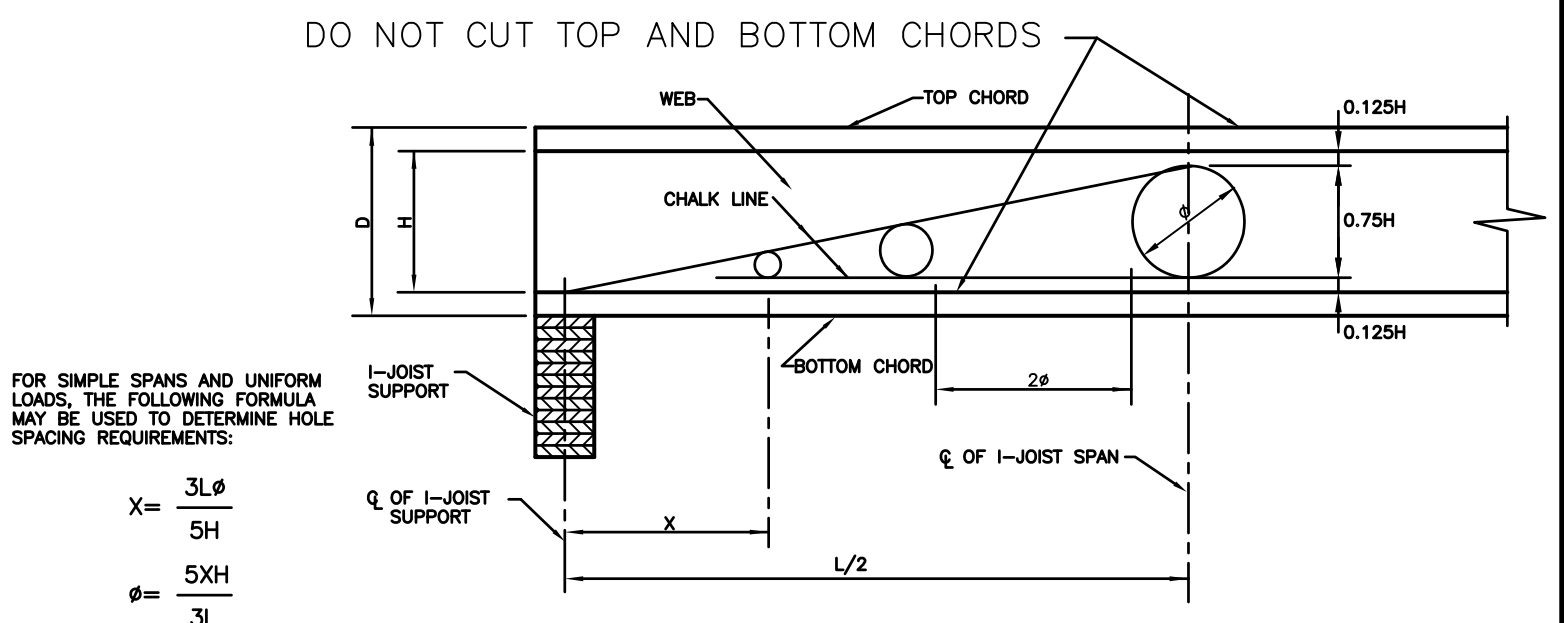

4 HOLE DETAIL

N.T.S.

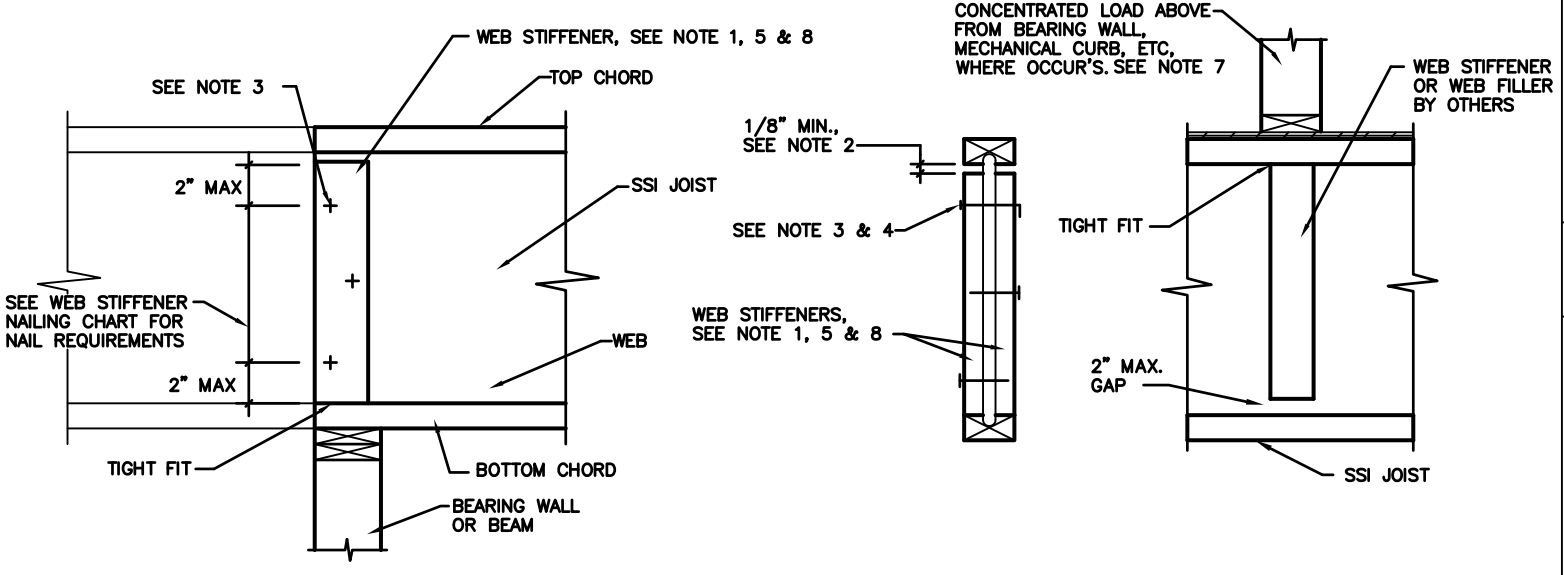

WEB STIFFENER NAILING CHART

JOIST DEPTH	3/8 INCH OSB, 7/16 INCH OSB
16	6-10d
18	8-10d
20	8-10d
22	8-10d
24	10-10d
26	10-10d
28	10-10d
30	10-10d

SEE NOTES 6, 7, 8 & 9

5 WEB STIFFENER ATTACHMENT

N.T.S.

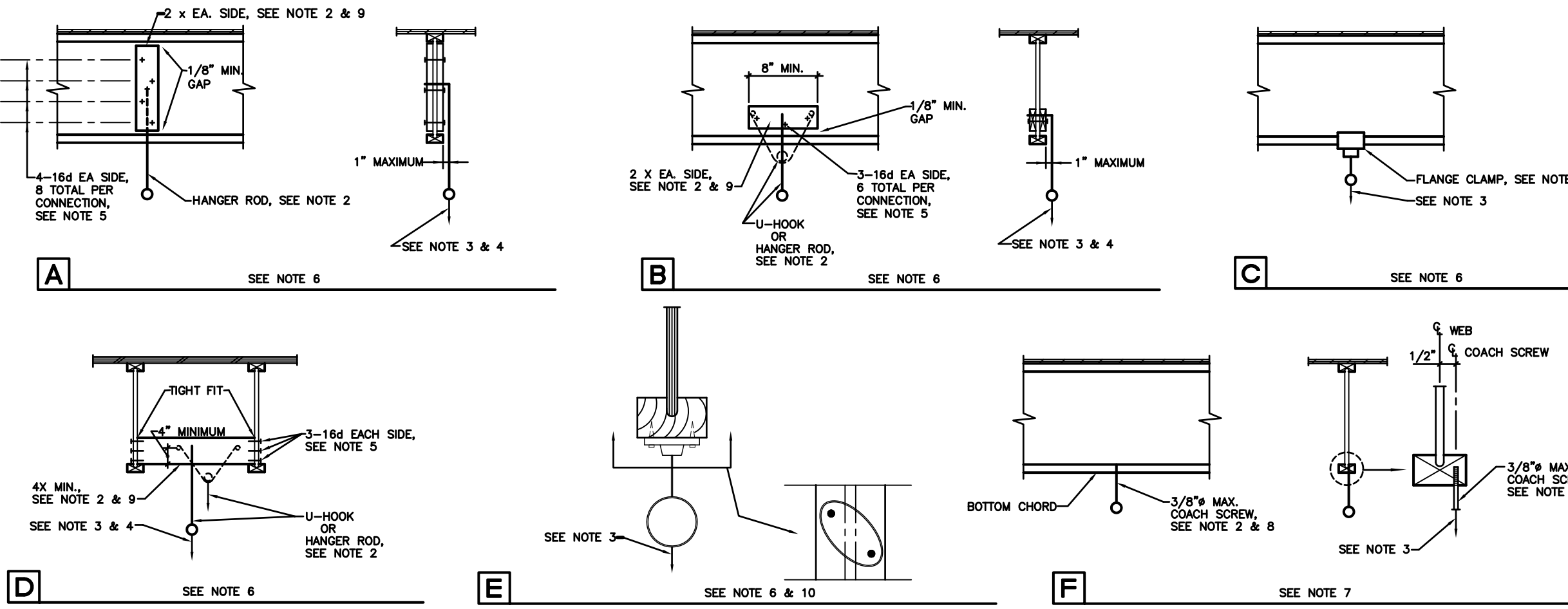

- DETAILS SHOWN MAY BE USED FOR SIMILAR LOADING SITUATIONS (I.e. JOIST SUPPORT, DRAIN PIPE SUPPORT, ETC.)
- D.F. STANDARD GRADE OR BETTER WEB FILLER AND HARDWARE BY OTHERS. DETAILS (D) THROUGH (F) ARE LIMITED TO A 2" DIAMETER PIPE AT MAX HANGER SPACING OF 15".
- I-JOIST CAPACITY MUST BE VERIFIED FOR CONCENTRATED LOADS BEYOND WHAT IS ALLOCATED WITHIN THE DESIGN CRITERIA.
- CAPACITY OF CONNECTION TO I-JOIST MAY BE INCREASED WITH ADDITIONAL NAILS OR BOLTS. VERIFY CAPACITY OF HARDWARE USED.
- NAILS USED ARE TO BE COMMON WIRE TYPE. NAILS MAY HAVE TO BE STAGGERED AND OR HOLES PREDRILLED TO PREVENT WEB FILLER FROM SPLITTING.
- CONNECTION (A) THRU (E) MAY BE USED ANYWHERE WITHIN THE JOIST SPAN.
- CONNECTION (F) TO BE LOCATED IN OUTER 1/3 OF SPAN.
- COACH SCREW TO BE INSTALLED INTO PREDRILLED HOLE. (DETAIL NOT TO BE USED WITH I-JOIST LESS THAN 2 1/2" WIDE)
- TO PREVENT DAMAGE TO I-JOIST, DO NOT NAIL AGAINST WEB WITHOUT PROPER BRACING.
- CEILING FLANGE WITH 2-18 GAUGE (0.294") x 1-1/2" WOOD SCREWS (1/8" PILOT HOLE REQUIRED) OR 2-1/4" x 2" LAG SCREWS (1/8" PILOT HOLE REQUIRED). OFFSET SCREWS AS SHOWN.
- FOR HIGHER FORCES THAN SHOWN, SEE LONGITUDINAL AND LATERAL SWAY BRACE DETAILS.
- NOTE: ALL CONNECTIONS, CLAMPS, HANGERS, RODS, OR SUPPORT ETC., SHALL BE IN ACCORDANCE WITH NFPA 13.

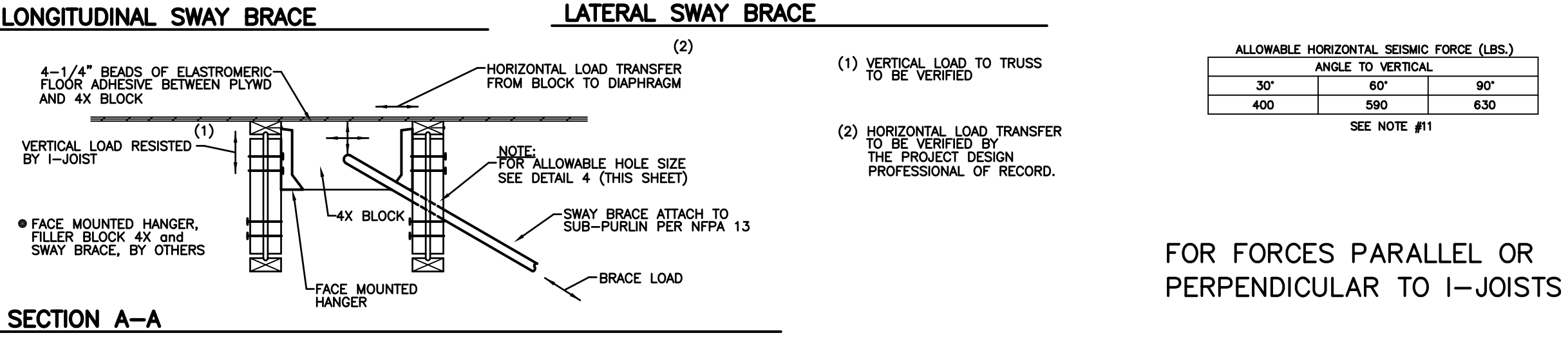
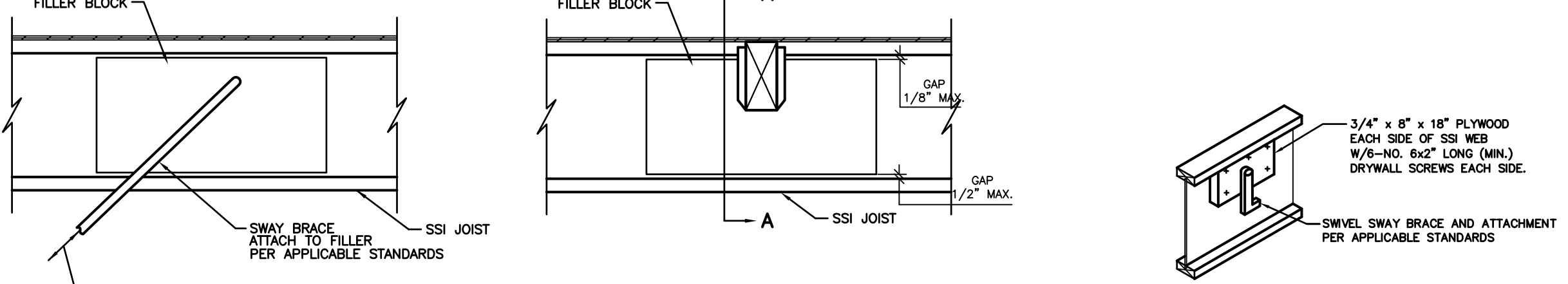

6 FIRE SPRINKLER ATTACHMENT

N.T.S.

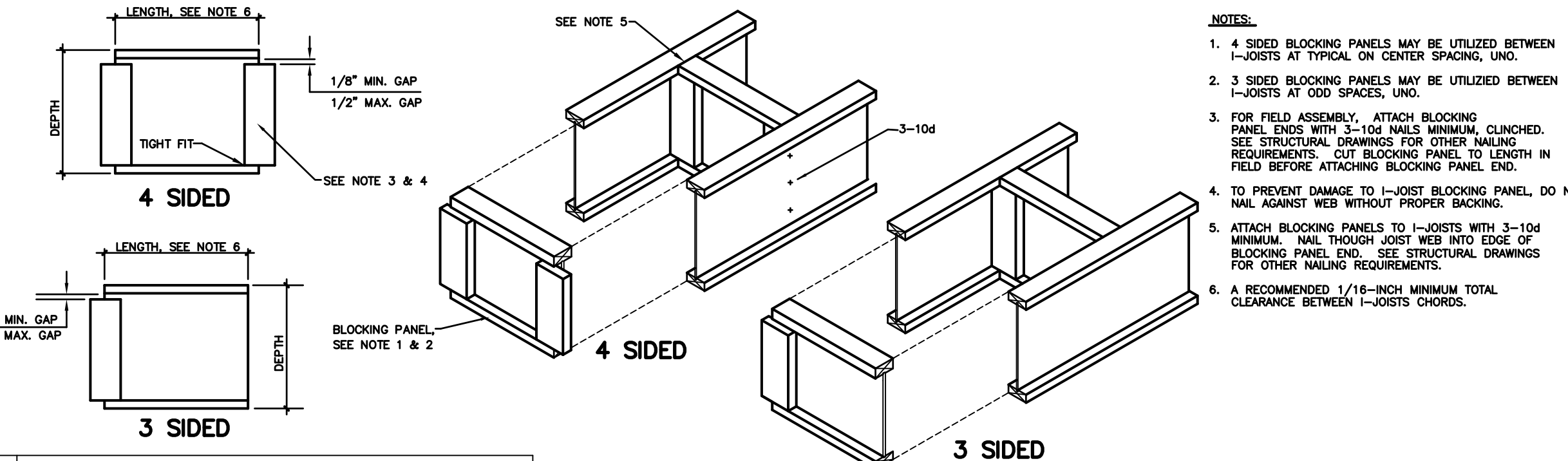

7 3 & 4 SIDED BLOCKING PANEL

N.T.S.

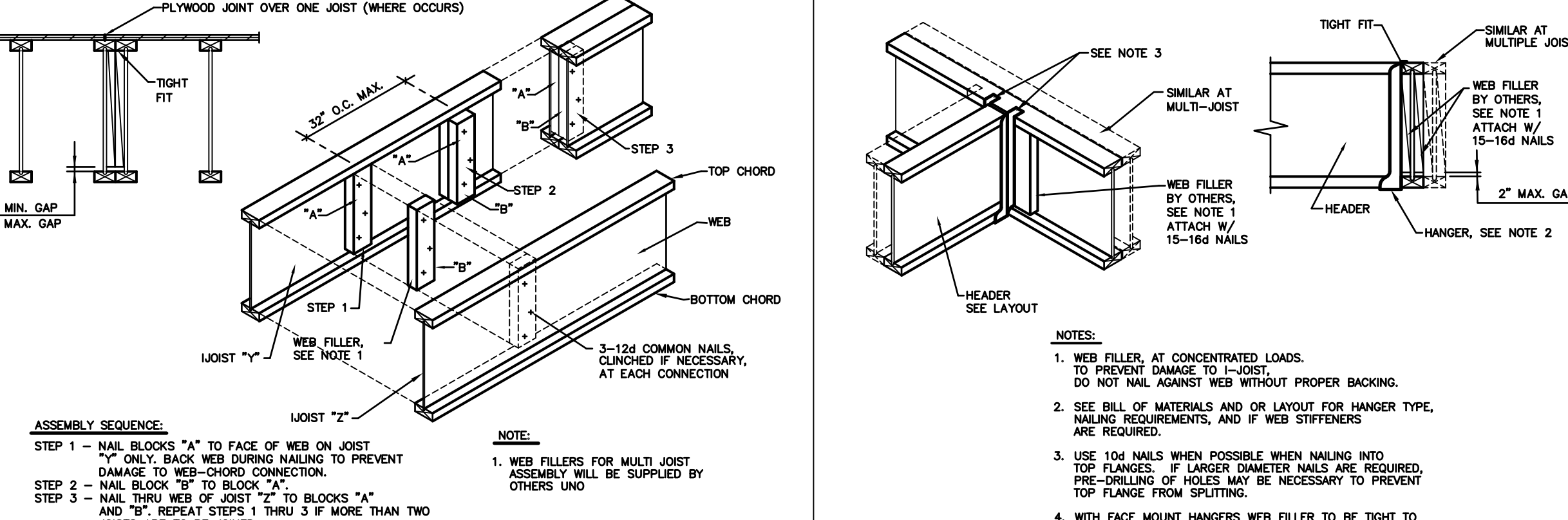

8 MULTI-JOIST ASSEMBLY

N.T.S.

9 HEAD-OUT DETAIL

I JOIST PRODUCT COVER SHEET

- AN I-JOIST IS AN ENGINEERED WOOD COMPONENT WITH WOOD CHORDS AND A SINGLE WEB OF VARYING THICKNESS, DEPENDING ON REQUIRED DESIGN. THE WEBS ARE GLUED AND INSTALLED BETWEEN THE TWO CHORDS. WEB BUTT JOINTS ARE GLUED TO FORM A CONTINUOUS WEB MEMBER. CONNECTION IS MADE BETWEEN THE WEB AND CHORD BY INSERTING THE WEB INTO SPECIALLY PREPARED GROOVES IN THE CHORDS WHICH ARE LOCATED IN ONE FACE OF THE CHORD. THE PROFILE OR SHAPE OF AN I-JOIST MAY BE CONSTANT OR SINGLE TAPERED.
- INTERMEDIATE WEB STIFFENERS ARE NOT REQUIRED EXCEPT AT LOCATIONS WHERE JOISTS ARE SUPPORTING CONCENTRATED LOADS. WEB STIFFENERS AT BEARING SUPPORT POINTS MAY NOT BE REQUIRED FOR CERTAIN I-JOISTS DEPTHS AND CONDITIONS. SEE DESIGN CALCULATIONS AND OR DETAILS WITHIN THE PLACEMENT PLAN DRAWINGS AND DETAILS.
- THE COMPRESSION CHORD MUST BE CONTINUOUSLY, LATERALLY SUPPORTED. THE ENDS OF THE JOISTS MUST BE RESTRAINED TO PREVENT ROLL OVER. THIS IS PROVIDED BY DIAPHRAGM SHEATHING ATTACHED TO THE TOP CHORD AND TO AN END WALL, OR SHEAR TRANSFER PANELS CAPABLE OF TRANSFERRING A MINIMUM FORCE OF 50 plf. BLOCKING OR CROSS BRIDGING WITH EQUIVALENT STRENGTH MAY BE USED.
- THE GLUE BOND BETWEEN THE CHORDS AND THE WEB IS CRITICAL TO THE PERFORMANCE OF THE I-JOIST. DO NOT POUND OUTWARD ON THE CHORDS.

JOBSITE HANDLING OF I-JOISTS

IT IS THE CUSTOMER'S RESPONSIBILITY TO UNLOAD THE I-JOISTS FROM THE TRUCK AND FOR ALL HANDLING THEREAFTER. THE I-JOIST WARRANTY ONLY APPLIES SO LONG AS THE PRODUCT IS NOT DAMAGED OR ALTERED IN ANY WAY AND IS INSTALLED IN A WORKMANLIKE MANNER AND ACCORDING TO INSTALLATION INFORMATION NOTED HEREON. I-JOISTS WILL BE DELIVERED TO THE JOBSITE IN BUNDLES BANNED TOGETHER FOR HANDLING. TO AVOID DAMAGE, THEY SHOULD BE KEPT IN THESE BUNDLES UNTIL THEY ARE READY TO BE INSTALLED IN THE STRUCTURE. NEVER HANDLE I-JOISTS FLAT, KEEP IN AN UPRIGHT POSITION.

STORAGE OF I-JOISTS

WALLS BEING STORED AT THE JOBSITE, KEEP I-JOISTS IN AN UPRIGHT POSITION. THE BUNDLES SHOULD BE SUPPORTED ON LEVEL STICKERS TO KEEP I-JOISTS OUT OF THE MUD AND DIRT. STACKING OF BUNDLES IS PERMITTED IF AN ADEQUATE NUMBER OF STICKERS IS PROVIDED TO PREVENT DAMAGE AND NORMAL SAFETY PRECAUTIONS ARE FOLLOWED.
ALL GLUE USED IN I-JOISTS IS WATER PROOF. I-JOISTS SHOULD RECEIVE THE SAME PROTECTION FROM WEATHER GIVEN OTHER WOOD PRODUCTS. HOWEVER, LONG EXPOSURE TO WATER AND SUN WILL CAUSE SOME DETERIORATION AND CHECKING OF WOOD.

JOIST NAILING CHART

NAIL TYPE	NAIL SIZE	FACE	EDGE
8d COMMON	0.1137x2 1/2"	2"	4"
10d COMMON	0.1317x2 1/2"	2"	6"
12d COMMON	0.1287x3 1/4"	2"	6"
16d COMMON	0.1487x3 1/4"	3"	6"
8d COMMON	0.1137x2 1/2"	2"	4"
10d COMMON	0.1317x2 1/2"	2"	6"
12d COMMON	0.1287x3 1/4"	2"	6"
16d COMMON	0.1487x3 1/4"	3"	6"



WARNING:

Drilling, sawing, sanding or machining wood products generates wood dust and other substances known to the State of California to cause cancer. Avoid inhaling dust generated from wood products or use a dust mask or other safeguards for personal protection.
Wood products emit chemicals known to the State of California to cause birth defects or other reproductive harm.

10 GENERAL I-JOIST INFORMATION

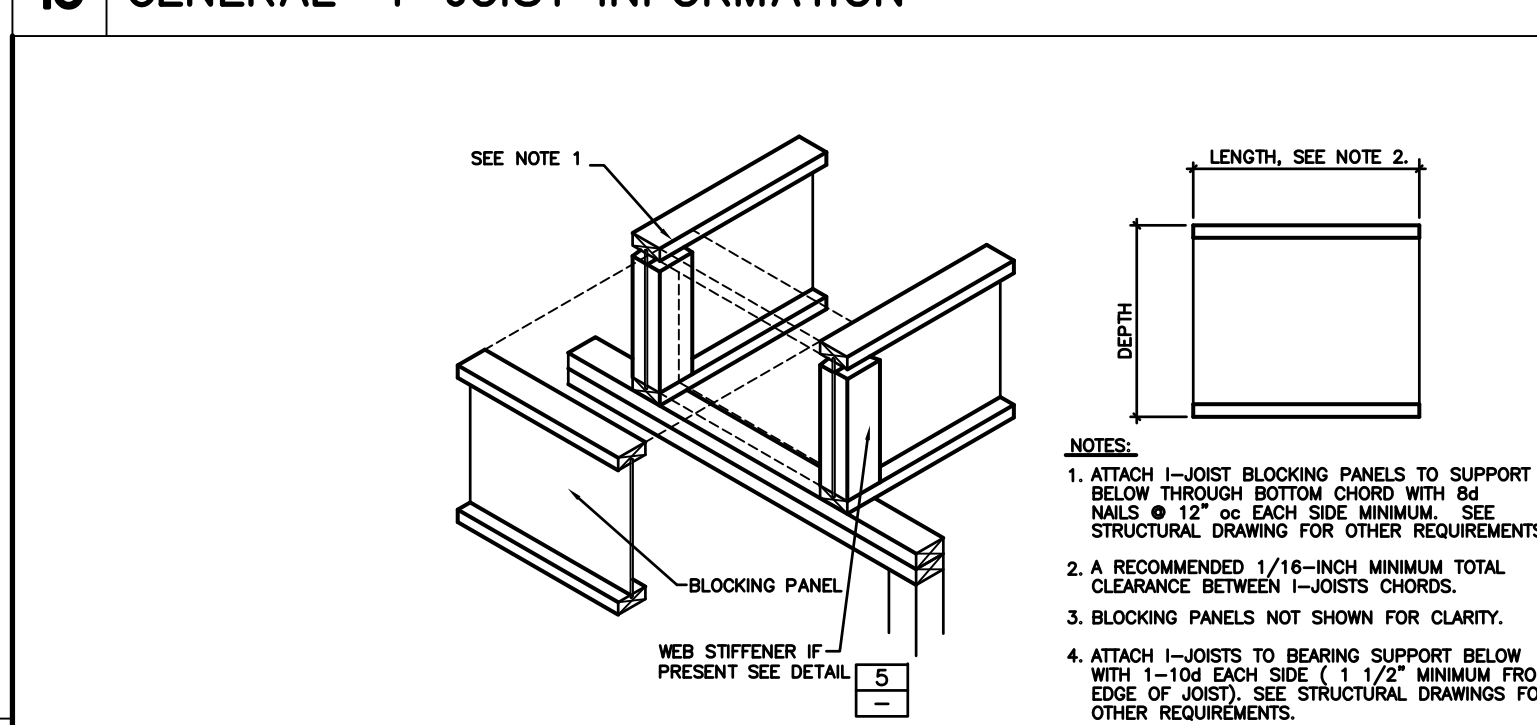

11 2 SIDED BLOCKING PANEL

- ### GENERAL NOTES:
- ALL CLOUDED NOTES, DIMENSIONS, ETC. REQUIRED VERIFICATION AND MUST BE MARKED EITHER "OR" OR THE CORRECT INFORMATION PROVIDED.
 - PLEASE BE AWARE THAT ANY CLOUDED ITEMS NOT ACKNOWLEDGED WILL REQUIRE TELEPHONE CALLS TO RESPONSIBLE PARTIES AND MAY CAUSE A DELAY IN THE MANUFACTURE OF YOUR ORDER.
 - PLEASE VERIFY THAT ALL INFORMATION PROVIDED HEREWITH REFLECTS THE LATEST AVAILABLE PROJECT INFORMATION AND THAT ALL I-JOIST LENGTHS CORRESPOND WITH ACTUAL FIELD DIMENSIONS.
 - DETAILS SHOW MINIMUM NAILING ALLOWED. REFER TO PROJECT PLANS FOR MORE STRINGENT NAILING REQUIREMENTS.
 - IN PREPARATION OF THESE SHOP DRAWINGS, WE HAVE RELIED UPON PLANS OR SPECIFICATIONS OR OTHER INFORMATION PREPARED BY REPRESENTATIVES OF THE OWNER AND CANNOT BE RESPONSIBLE IF THE INFORMATION FURNISHED IS ERRONEOUS. BUYER OR HIS AGENT SHALL APPROVE THESE SHOP DRAWINGS FOR DIMENSIONS, QUANTITIES, SPECIFICATIONS AND DETAILS.
 - I-JOISTS ARE IN ACCORDANCE WITH THE CURRENT ADOPTED EDITION OF THE IBC, CBC, AND NATIONAL DESIGN SPECIFICATION AND CONFORM TO A CURRENT ICC-ES REPORT.
- ### LEGEND / ABBREVIATIONS
- SEE PROJECT PLANS FOR OTHER ABBREVIATIONS AND SYMBOLS USED.
- DETAIL (ON SHOP DRAWINGS)
PROJECT PLAN DETAIL (PER PLANS)
START I-JOIST LAYOUT @ o/c SPACING
DIRECTION OF ROOF SLOPE
- FMB = FRAMING MATERIAL BY OTHERS
VF = VERIFY IN FIELD
NIC = NOT IN CONTRACT
UNO = UNLESS NOTED OTHERWISE
FSM = FIRE SPRINKLER MAIN LINE
LBS = POUNDS
PSF = POUNDS PER SQUARE FOOT
PLF = POUNDS PER LINEAL FOOT
MFR. = MANUFACTURER
o/c, c.c. = ON CENTER [SPACING]
BOM = BILL(S) OF MATERIAL (8 1/2 x 11 SHEETS)
DBL = DOUBLE MEMBER (TPL = TRIPLE MEMBER)

REVISIONS
GROCERY OUTLET STORE #321 (GVP)
2308 DEL PASO BLVD
SACRAMENTO, CA 95815

ENGINEER
SKYLINE ARCHITECTS
916-435-2800
ARCHITECT
HMR ARCHITECTS
916-736-2724
CUSTOMER
SD OCHS CONSTRUCTION INC
916-660-9480

G2 NATIONAL
Evolution in Wood-Framed Structure.
G2 NATIONAL LLC
2185 GREEN VALLEY DRIVE # 212 SPARKS, NEVADA 89431.
PN-13168
SHEET
2 OF 5

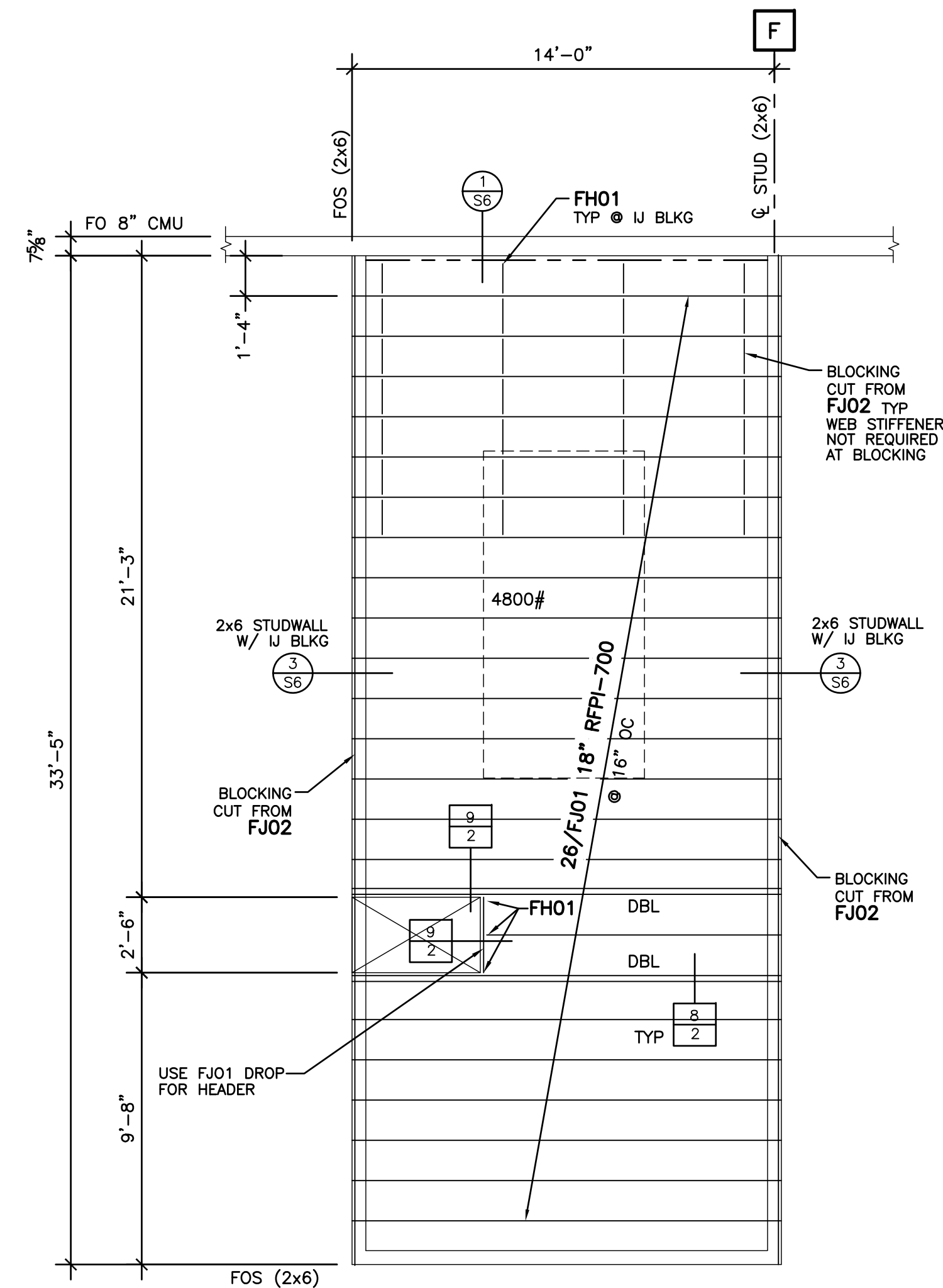

EQUIPMENT PLATFORM
PRODUCT PLACEMENT PLAN

(REF: S3)
SCALE: 1/4" = 1'-0"

DESIGN LOADS		
	FLOOR	
LIVE LOAD	50	PSF
PART LOAD	-	PSF
DEAD LOAD	8	PSF
TOTAL LOAD	58	PSF

DESIGN DEFLECTION:
 $\Delta_{LL} \leq L/360$ $\Delta_{TL} \leq L/240$
 LOAD DURATION FACTOR = 1.0
 DESIGN CODE: CBC 2016

PROJECT PLANS USED:	
SHEETS	DATE
ARCHITECTURAL DRAWINGS A-0.0 THRU A-7.3	07/27/17
STRUCTURAL DRAWINGS S1 THRU S12	07/27/17

NOTE: MISC WEB STIFFENERS/FILLERS/
BACKERS ARE BY OTHERS TYPICAL

NOTE: SPRINKLER LINES GREATER THAN
3" DIAMETER HAVE NOT BEEN CONSIDERED
IN THE TRUSS DESIGNS

ROSEBURG FOREST PRODUCTS I-JOIST ESR-1251			
QTY	MARK	DESCRIPTION	LENGTH
26	FJ01	18" RFP1-700	15'-0"
9	FJ02	18" RFP1-700	12'-0"

FABE=field attach both ends

FABE WS01
(FIELD CUT BLKG)

KC METALS CONNECTORS ESR-2930					
QTY	MARK	DESCRIPTION	NAILING		REMARKS
			HEADER	JOIST	
59	FH01	MTR3518	6-10d x 1 1/2	2-10d x 1 1/2	SINGLE

WEB STIFFENERS			
QTY	MARK	DESCRIPTION	LENGTH
108	WS01	PLY 7/8 x 3 1/2	1'-2 3/4"

REVISIONS	
NO.	DESCRIPTION
1	2-27-18 Per approved drawings and G2 review
2	
3	
4	
5	

GROCERY OUTLET STORE #321 (GVP)
2308 DEL PASO BLVD
SACRAMENTO, CA 95815

ENGINEER: SKYB
916-429-2900
ARCHITECT: HMR ARCHITECTS
916-736-2724
CUSTOMER: SD OCHS CONSTRUCTION INC
916-660-3480

G2 NATIONAL
Evolution in Wood-Framed Structure.[®]
G2 NATIONAL LLC
2105 GREEN VISTA DRIVE # 212 SPARKS, NEVADA 89431

11/02/2017
PN-13168
SHEET
3 OF 5

REVISED FOR CONSTRUCTION

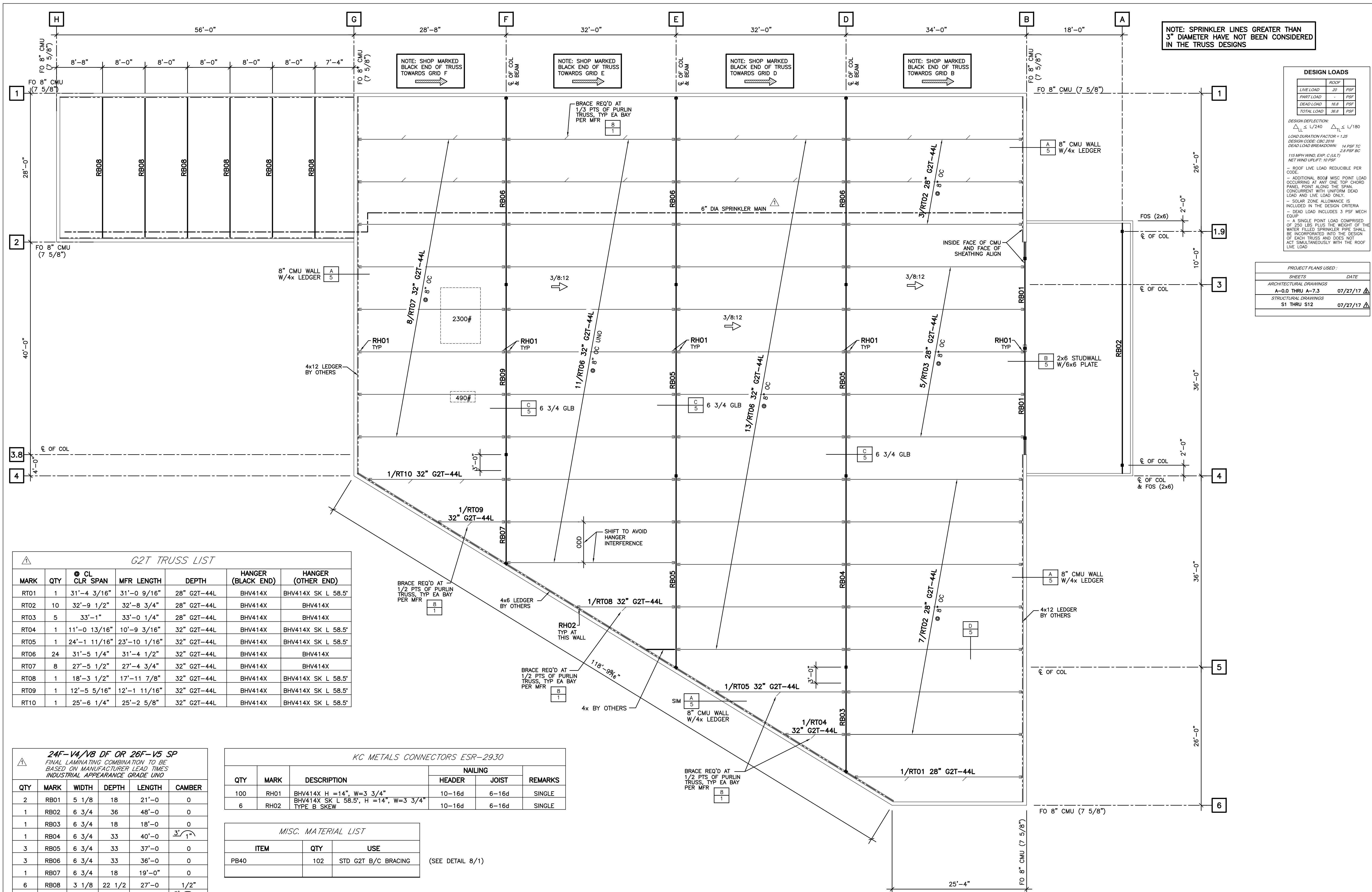

NOTE: SPRINKLER LINES GREATER THAN 3" DIAMETER HAVE NOT BEEN CONSIDERED IN THE TRUSS DESIGNS

DESIGN LOADS

LOAD TYPE	ROOF	PSF
LIVE LOAD	20	PSF
PART LOAD	-	PSF
DEAD LOAD	16.8	PSF
TOTAL LOAD	36.8	PSF

DESIGN DEFLECTION:
 $\Delta_{LL} \leq L/240$ $\Delta_{TL} \leq L/180$
 LOAD DURATION FACTOR = 1.25
 DESIGN CODE: CRC 3016
 DEAD LOAD BREAKDOWN: 14 PSF TC
 2.8 PSF BC
 115 MPH WIND, EXP. C (LLT) 2.8 PSF MECH
 NET WIND UPLIFT: 10 PSF
 - ROOF LIVE LOAD REDUCIBLE PER CODE
 - ADDITIONAL ROOF MISC POINT LOAD OCCURRING AT ANY ONE TOP CHORD PANEL POINT ALONG THE SPAN, CONCURRENT WITH UNIFORM DEAD LOAD AND LIVE LOAD ONLY.
 - SOLAR ZONE ALLOWANCE IS INCLUDED IN THE DESIGN CRITERIA
 - DEAD LOAD INCLUDES 3 PSF MECH EQUIP
 - A SINGLE POINT LOAD COMPRISED OF 250 LBS PLUS THE WEIGHT OF THE WATER FILLED SPRINKLER PIPE SHALL BE INCORPORATED INTO THE DESIGN OF EACH TRUSS AND DOES NOT ACT SIMULTANEOUSLY WITH THE ROOF LIVE LOAD

PROJECT PLANS USED:

SHEETS	DATE
ARCHITECTURAL DRAWINGS	
A-0.0 THRU A-7.3	07/27/17
STRUCTURAL DRAWINGS	
S1 THRU S12	07/27/17

REVISIONS

NO.	DESCRIPTION
1	2-27-18 per approved drawings and G2 Review

GROCERY OUTLET STORE #321 (GVP)
 2308 DEL PASO BLVD
 SACRAMENTO, CA 95815

ENGINEER: SKY 916-493-2800
 ARCHITECT: HMR ARCHITECTS 916-736-2724
 CUSTOMER: SD OCHS CONSTRUCTION INC 916-660-9480

G2 NATIONAL
 Evolution in Wood-Framed Structure.
 G2 NATIONAL LLC
 2165 GREEN VISTA DRIVE # 212 SPARKS, NEVADA 89431

G2T TRUSS LIST

MARK	QTY	CL CLR SPAN	MFR LENGTH	DEPTH	HANGER (BLACK END)	HANGER (OTHER END)
RT01	1	31'-4 3/16"	31'-0 9/16"	28" G2T-44L	BHV414X	BHV414X SK L 58.5'
RT02	10	32'-9 1/2"	32'-8 3/4"	28" G2T-44L	BHV414X	BHV414X
RT03	5	33'-1"	33'-0 1/4"	28" G2T-44L	BHV414X	BHV414X
RT04	1	11'-0 13/16"	10'-9 3/16"	32" G2T-44L	BHV414X	BHV414X SK L 58.5'
RT05	1	24'-1 11/16"	23'-10 1/16"	32" G2T-44L	BHV414X	BHV414X SK L 58.5'
RT06	24	31'-5 1/4"	31'-4 1/2"	32" G2T-44L	BHV414X	BHV414X
RT07	8	27'-5 1/2"	27'-4 3/4"	32" G2T-44L	BHV414X	BHV414X
RT08	1	18'-3 1/2"	17'-11 7/8"	32" G2T-44L	BHV414X	BHV414X SK L 58.5'
RT09	1	12'-5 5/16"	12'-1 11/16"	32" G2T-44L	BHV414X	BHV414X SK L 58.5'
RT10	1	25'-6 1/4"	25'-2 5/8"	32" G2T-44L	BHV414X	BHV414X SK L 58.5'

24F-V4/V8 DF OR 26F-V5 SP
 FINAL LAMINATING COMBINATION TO BE BASED ON MANUFACTURER LEAD TIMES INDUSTRIAL APPEARANCE GRADE UNO

QTY	MARK	WIDTH	DEPTH	LENGTH	CAMBER
2	RB01	5 1/8	18	21'-0	0
1	RB02	6 3/4	36	48'-0	0
1	RB03	6 3/4	18	18'-0	0
1	RB04	6 3/4	33	40'-0	3/1"
3	RB05	6 3/4	33	37'-0	0
3	RB06	6 3/4	33	36'-0	0
1	RB07	6 3/4	18	19'-0	0
6	RB08	3 1/8	22 1/2	27'-0	1/2"
1	RB09	6 3/4	33	36'-0	3/1"

KC METALS CONNECTORS ESR-2930

QTY	MARK	DESCRIPTION	NAILING		REMARKS
			HEADER	JOIST	
100	RH01	BHV414X H = 14", W = 3 3/4"	10-16d	6-16d	SINGLE
6	RH02	BHV414X SK L 58.5', H = 14", W = 3 3/4" TYPE B SKEW	10-16d	6-16d	SINGLE

MISC. MATERIAL LIST

ITEM	QTY	USE
PB40	102	STD G2T B/C BRACING (SEE DETAIL 8/1)

ROOF PRODUCT PLACEMENT PLAN

(REF: S4)
 SCALE: 1/8" = 1'-0"

REVISED FOR CONSTRUCTION

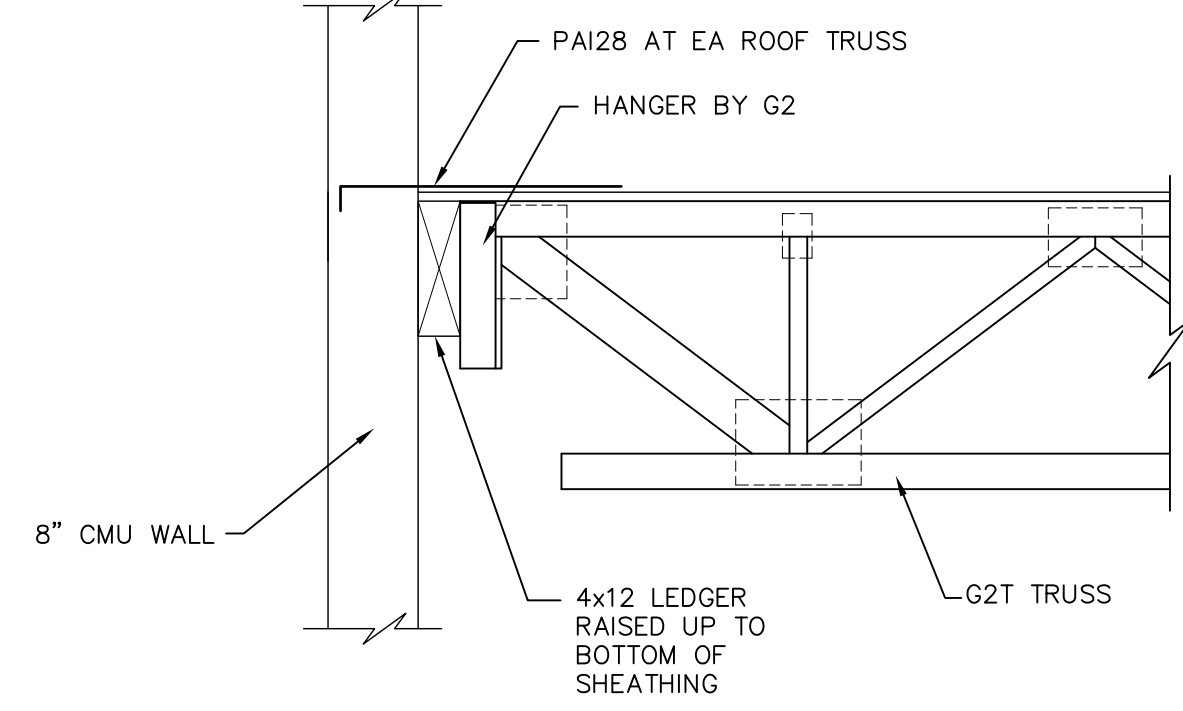

REF: 1/S7, 5/S7, 6/S7, 1/S8, 6/S10

A
-

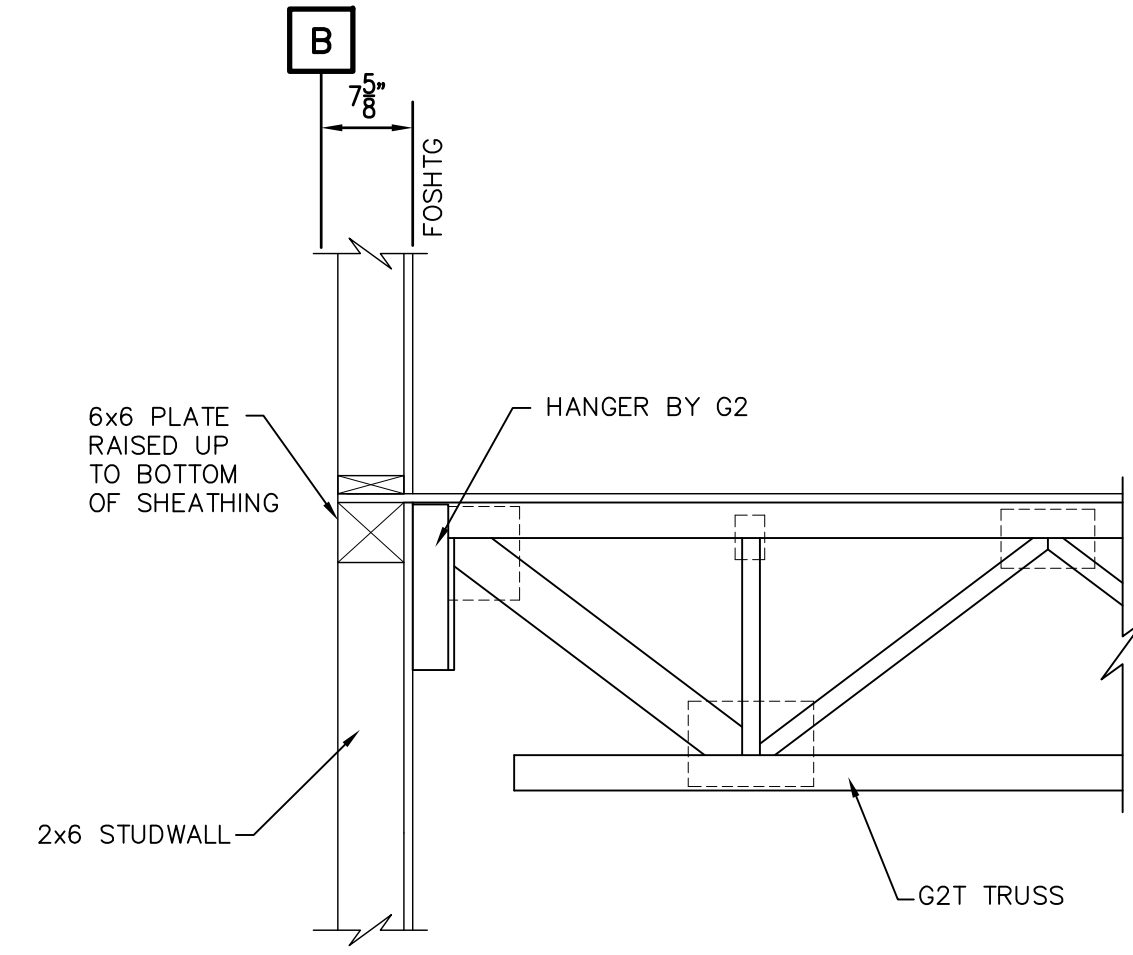

REF: 2/S8

B
-

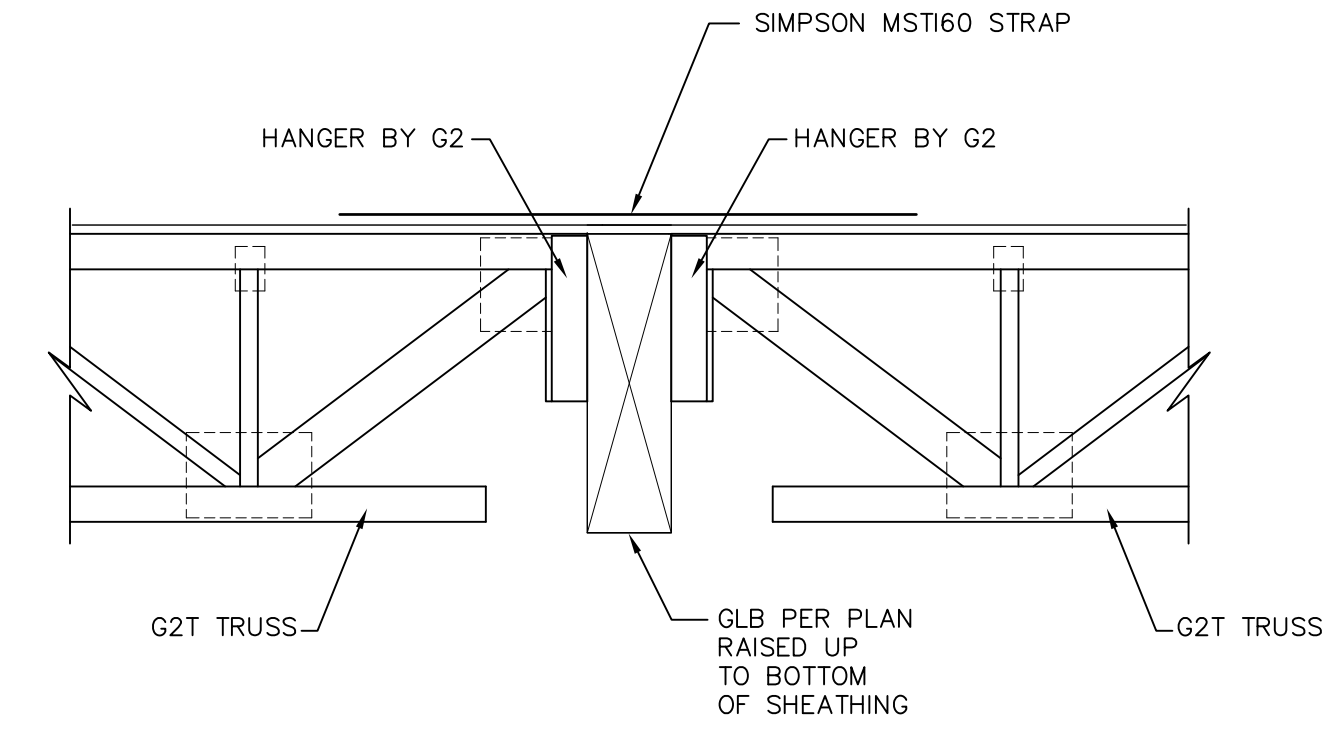

REF: 3/S7, 4/S7

C
-

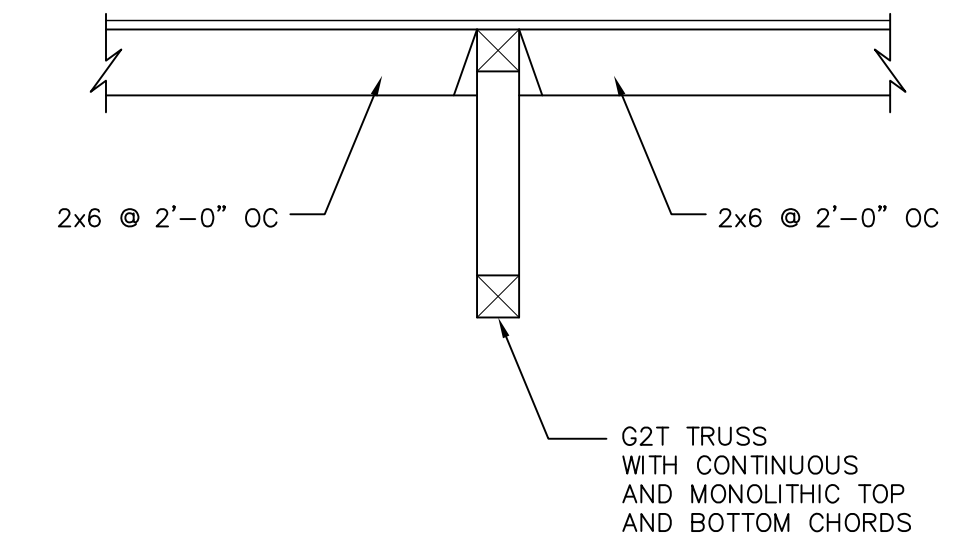

REF: 4/S10

D
-

REVISIONS	
12-14-17	Per approved drawings
△	
△	
△	
△	

GROCERY OUTLET STORE #321 (GVP)
 2308 DEL PASO BLVD
 SACRAMENTO, CA 95815

ENGINEER
 SWAN QUARTES
 916-439-2800

ARCHITECT
 HME ARCHITECTS
 916-736-2724

CUSTOMER
 JOCHS CONSTRUCTION INC
 916-860-9480

G2 NATIONAL
 Evolution in Wood-Framed Structure.[®]
 G2 NATIONAL LLC
 2785 GREEN VISTA DRIVE # 212 SPARKS, NEVADA 89431.

PN-13168
 SHEET
 5 OF 5

REVISED FOR CONSTRUCTION